

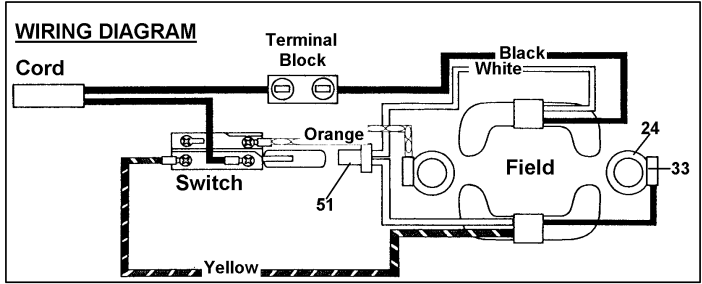

5" GRINDER (W/Brake & Clutch)AC/DC

Model 9015A(MJ)

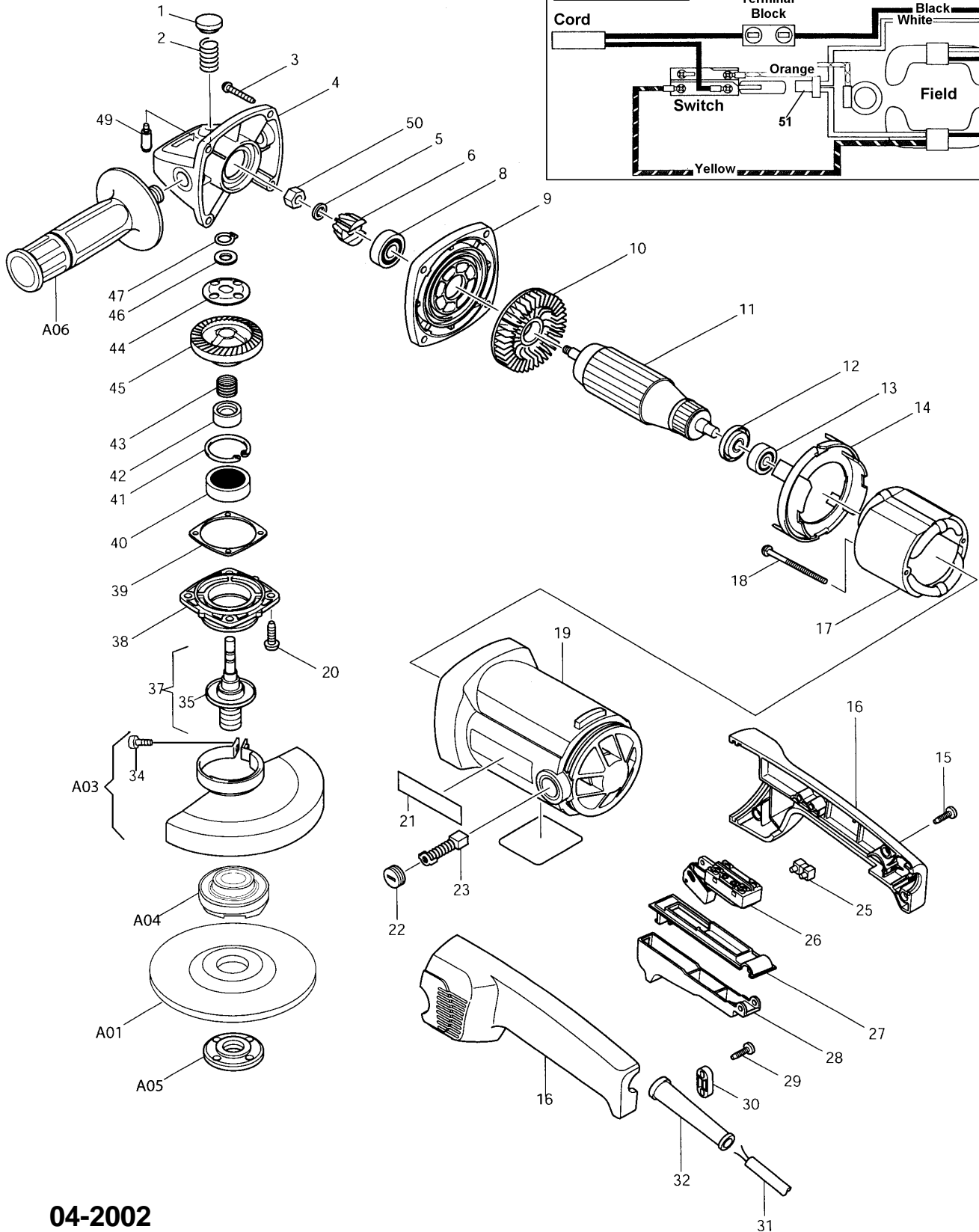

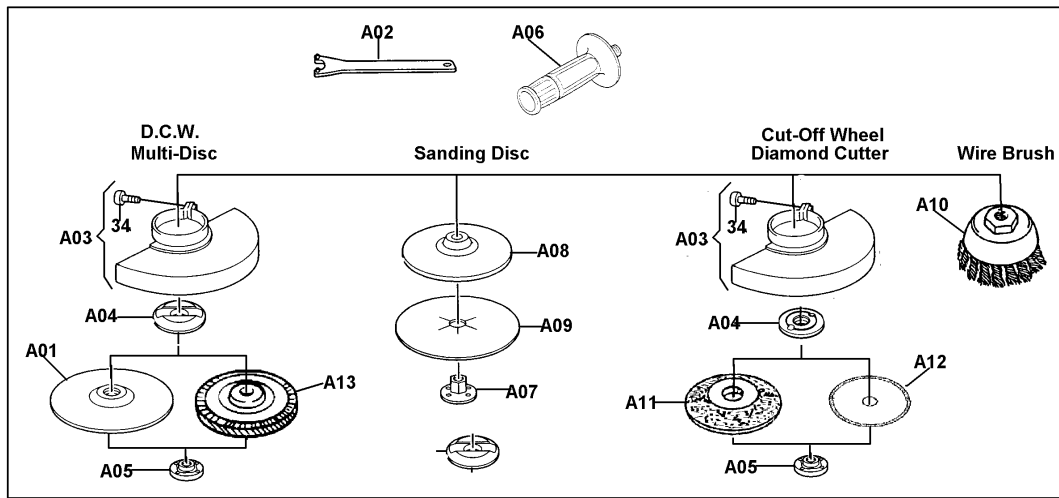

Item No.	Part No.	No. Used	Description	Item No.	Part No.	No. Used	Description
1	416449-8	1	Pin Cap	39	442126-6	1	Gasket
2	233089-5	1	Compression Spring 12	40	211236-8	1	Ball Bearing 6002DDW
3	266173-1	4	Tapping Screw 5X30	41	962151-6	1	Retaining Ring R-32
4	*	1	Gear Housing Com.	42	324077-4	1	Lock Sleeve
5	941152-7	1	Flat Washer 6	43	233905-1	1	Lock Spring 17
6	226755-1	1	Spiral Bevel Gear 12	44	267757-8	1	Lock Washer
	183317-7	1	Spiral Bevel Gear Set (Includes Item 6 & 45)	45	227404-3		Spiral Bevel Gear 33
8	211131-2	1	Ball Bearing 6001DDW		183317-7	1	Spiral Bevel Gear Set (Includes Item 6 & 45)
9	317433-5	1	Gear Housing Cover	46	253215-0	1	Flat Washer 8
10	240010-7	1	Fan 70	47	961004-6	1	Retaining Ring S-8
11	516411-4	1	Armature Assy (Includes Item 10, 12 & 13)	49	256446-0	1	Pin 6
12	681644-1	1	Insulation Washer	50	931303-0	1	Hex. Nut M6
13	210005-4	1	Ball Bearing 608DDW	51	654509-0	1	Closed End Terminal 2-SD
14	416448-0	1	Baffle Plate	Accessories			
15	265995-6	4	Tapping Screw 4X18	A01	-----	1	5" Depressed Center Wheel (See Catalogue for Details)
16	183274-9	1	Handle Set	A02	782412-6	1	Lock Nut Wrench 28
17	522851-6	1	Field Assy [Includes Items 24(1pc) & 33(1pc)]	A03	125097-9	1	Wheel Cover Assy (Includes Item 34)
18	266029-8	2	Tapping Screw 5X65	A04	224368-2	1	Inner Flange 45 (Type 1) (For D.C.W., Multi Disc. C.O.W. & Diamond Wheel)
19	183159-9	1	Motor Housing (Includes Item 21 & 2X643708-9 -Brush Holder 5-11)		224378-9	1	Inner Flange 45 (Type 2) (For D.C.W., Multi Disc. C.O.W. & Diamond Wheel)
20	*	4	Screw	* When replacing Inner Flange make sure to use same Type of Lock Nut			
21	819001-5	2	Makita Label	A05	224566-8	1	Lock Nut 5/8" - 45 (Type 1) (For D.C.W., Multi Disc, C.O.W., Diamond Wheel)
22	643750-0	2	Brush Holder Cap		224568-4	1	Lock Nut 5/8" - 45 (Type 2)(For D.C.W., Multi Disc, C.O.W., Diamond Wheel)
23	191979-7	2	Carbon Brush CB-311(2pcs/Set)	* When replacing Lock Nut make sure to use same Type of Inner Flange			
24	654020-2	2	Ring Terminal				
25	654532-5	1	Terminal Block 1P				
26	651055-4	1	Switch AC/DC				
27	417313-6	1	Switch Base				
28	417314-4	1	Switch Lever				
29	265995-6	2	Tapping Screw 4X18				
30	687063-9	1	Strain Relief				
31	664213-3	1	Cord With Plug 2P-16-2.5M				
32	682505-8	1	Cord Guard 10-90				
33	654501-6	2	Connector P-1.25				
34	251391-4	1	P.H. Screw M5X16				
35	344942-1	1	Labyrinth Ring				
37	152684-1	1	Spindle Com. (Includes Item 35)				
38	317396-5	1	Bearing Box				

Item No.	Part No.	No. Used	Description	Item No.	Part No.	No. Used	Description
A06	152492-0	1	Grip 36 Com.	A11	-----	1	5" C.O.W. (See Catalogue for Details)
A07	224517-1	1	Lock Nut 48 (For Abrasive Disc)	A12	-----	1	5" Diamond Wheel (See Catalogue for Details)
A08	743015-1	1	Rubber Pad (For 5" Abrasive Disc)	A13	-----	1	5" Multi-Disc (See Catalogue for Details)
A09	-----	1	5" Abrasive Disc (See Catalogue for Details)				
A10	-----	1	Wire Cup Brush (See Catalogue for Details)				

* SEE SERVICE CHANGES

SERVICE CHANGES

1. Change on Tapping Screws for securing Bearing Box to Gear Housing

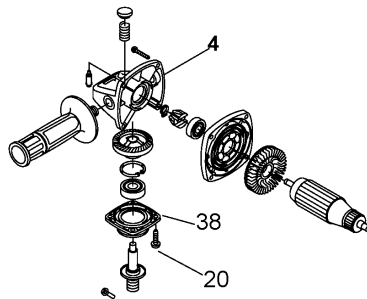

Type 1

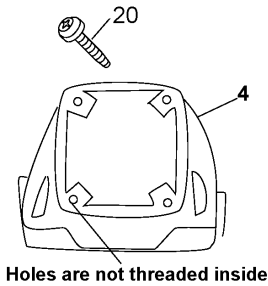

Type 2

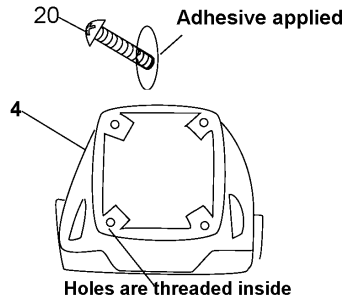

Item No.	Description	Type 1	Type 2
4	Gear Housing Com.	159995-5	153374-9
		(Includes 212043-2 - Needle Bearing 810) (Items 1, 2 & 49 - NOT INCLUDED)	
20	Screw	266027-2 - Tapping Screw CT 5X16	265096-0 - P.H. Screw M5X16
	Serial #	~ 2125E	2126E ~

Above parts are completely interchangeable as a set.